

AM1/AN-4A

cylindrical inductive



Micro Detectors

Italian Sensors Technology



Indicative image



Detection properties

| | |
|--------------------------|--|
| Nominal sensing distance | 8mm |
| Operanting distance | 0...6,4mm |
| Standard target | 24x24mm FE360 |
| Correction Factor | rame: 0,41 / alluminio: 0,46 / ottone: 0,52 / acciaio INOX: 0,71 |
| Thermal drift of Sr | < 10% |
| Repeat Accuracy | 5% (UB 24V Ta=23°C ±5°C) |
| Hysteresis | 1 ... 20% |

Outputs

| | |
|---------------------|-----------|
| Output type | PNP + NPN |
| Output Function | NO + NC |
| Switching frequency | 2kHz |

Electrical data

| | |
|------------------------------------|------------------------------|
| Operating Voltage | 10 - 30Vdc |
| No-Load supply current | ≤ 10mA |
| Load current | ≤ 200mA |
| Leakage current | ≤ 10μA |
| Output voltage drop | ≤ 1,8V @200mA |
| Max ripple content | ≤10% |
| LED indicators | LED giallo stato dell'uscita |
| Time delay before availability | 50ms |
| Short-circuit protection | Si |
| Reverse Polarity Protection | Si |
| Protection against inductive loads | Yes |

Mechanical data

| | |
|-----------------------|------------------------------|
| Dimensions | M12 x 1 / L= 49,8mm |
| Mounting | Non Schermato |
| Weight | 70g |
| Housing Material | Ottone nichelato |
| Connections | Cavo PVC 2m - Uscita Assiale |
| Active Head Material | PBT |
| Tightening torque | 10Nm |
| Operating temperature | -25°C...+70°C |

Test/Approvals

| | |
|-----------------------|--|
| Approvals | CE UR |
| EMC compatibility | IEC 60947-5-2 |
| Shocks and vibrations | Vibrazioni IEC 60068-2-6 / Urti IEC 60068-2-27 |
| Degree of protection | IP 67 (EN60529) |

Accessories

| | |
|----------------------|----------------|
| Supplied Accessories | 2 ghiera M12x1 |
|----------------------|----------------|

ELECTRICAL DIAGRAMS OF THE CONNECTIONS

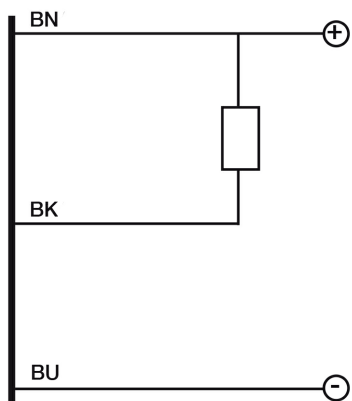

INSTALLATION

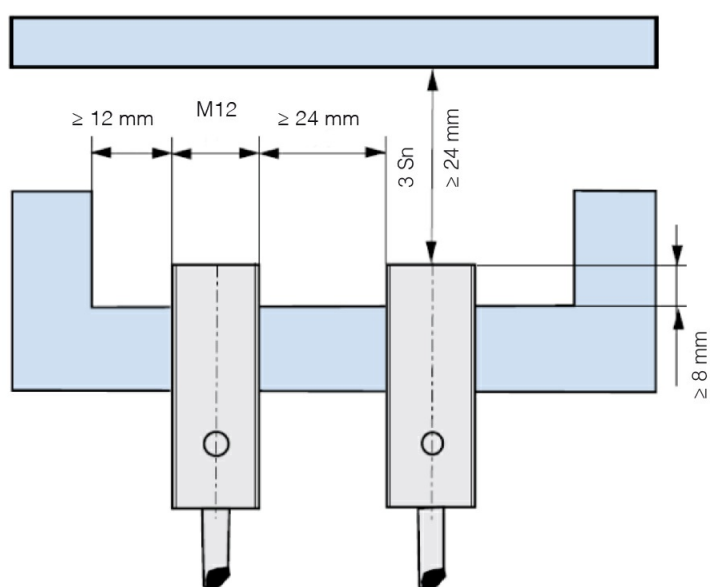

RESPONSE CURVES

Disassamento Parallelo

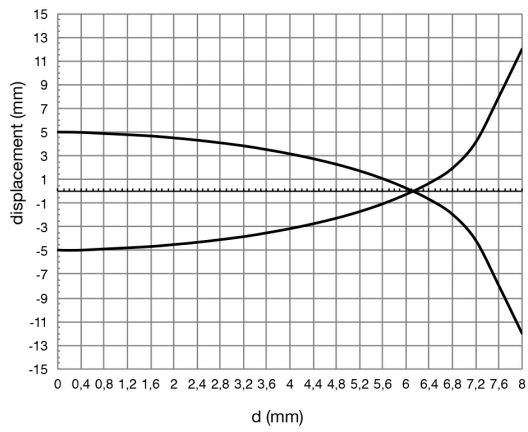

M.D. Micro Detectors S.p.A.

Strada S. Caterina, 235

41122 Modena (MO)

Tel. 059 420411

Fax 059 253973

E-mail info@microdetectors.com

date of printing

04/07/2019 13:20:21